



Universal I/O Expansion Module HY-TTC 48XS

Functional Safety
PL d

Description

The HY-TTC 48XS module is an intelligent I/O module which is certified according to CiA DSP 304 via CANopen Safety and which can be driven and parameterized according to CiA DSP 401.

The HY-TTC 48XS module was developed in accordance with the international standard ISO/EN 13849 and is certified by TÜV NORD. Therefore, it meets the requirements of safety levels PL d (Performance Level d).

For the CPU, it uses the safety CPU XC2287M which was specially developed by Infineon for safety applications. This offers enhanced safety features for the protection of the internal RAM and Flash memories.

The module is protected by the well-proven, robust and compact housing, specially designed for the off-highway automotive industry.

Special features

- PL d
- Additional watchdog CPU
- 48 inputs and outputs:
 - 16 power outputs
 - 4 current measurement inputs
 - 8 analogue inputs: voltage/current
- - 8 analogue inputs: voltage, configurable
- All inputs and outputs are configurable and are protected against overvoltage and short circuits
- Stabilized, adjustable sensor voltage supply with internal monitoring
- No reset caused by dip in voltage when starting engine
- Robust aluminium die-cast housing with a waterproof 80-pole male connection and pressure equalization via a waterproof Gore-Tex® membrane

Technical data

Ambient conditions	
Operating temperature	-40 .. +85 °C (full load) to EN 60068-2
Operating altitude	0 .. 4,000 m
Supply voltage	8 .. 32 V
Permitted voltage drop	up to ≥4 V (U _{BAT}) without reset to ISO 7637-1 (for engine start in 12 V systems)
Peak voltage	45 V max. (1 ms)
Idle current	0.15 A max. at 9 V
Standby current	0.5 mA max.
Current consumption	25 A max. (complete voltage and temperature range)
Fulfils the following standards	
CE - mark	Compliant with 2004/108/EC
E-mark	Compliant with 2009/19/EC
Functional safety	EN ISO 13849 PL d
EMC	ISO 13766 (up to 100 V/m, 20 MHz .. 1 GHz)
ESD	IEC 61000-4-2
Load dump	ISO 7637-2, 173V, 2 Ohm
Protection class	EN 60529 IP 65 / IP 67 DIN 40050 IP 6k9k
Temperature	EN 60068-2-1; -14Nb; -2; -78; -30
Vibration, Shock, Bump	IEC 60068-2-29; -64; -27; -32
Dimensions and weight	
Housing dimensions	148 x 181 x 40 mm
Minimum clearance for connection	198 x 203 x 40 mm
Weight:	664 g
Features*	
16-Bit Infineon XC2287M microcontroller, 80 MHz, 832 kB int. flash, 50 kB int. RAM, 512 kB ext. RAM, 8 KByte EEPROM	
Watchdog CPU freescale HC 908, including monitoring software	
CRC checker for supervising flash memory, Integrated Memory Protection Unit (MPU), Error-Correcting Code (ECC)	
1 x CAN, up to 1 Mbit/s	
8 x Analogue-IN 0 .. 5 V or 4 .. 20 mA / 10 bit, configurable via software	
8 x Analogue-IN 0 .. 32 V / 10 bit, range configurable via software	
4 x current measurement, configurable as 4 x Digital-OUT / 2 A low-side	
4 x Timer-IN (timer input 0.1 Hz .. 10 kHz)	
8 x Digital-IN	
8 x PWM-OUT 2 A high-side, configurable as 8 x timer inputs	
8 x Digital-OUT 4 A high-side, configurable as 8 x Analogue-IN	
Internal monitoring of board temperature, sensor supply and battery voltage	
52-pol. Tyco PN 1393450-5 / 28-pol. Tyco PN 1393436-4	
1 x sensor supply 8.5 V / 10.0 V (30 mA) / 14.5 V (40 mA) configurable	
2 x sensor supply 5 V (30 mA)	

Note: * All I/Os and interfaces are protected against short circuit to GND and BAT+.

Block circuit diagram

HY-TTC 48XS

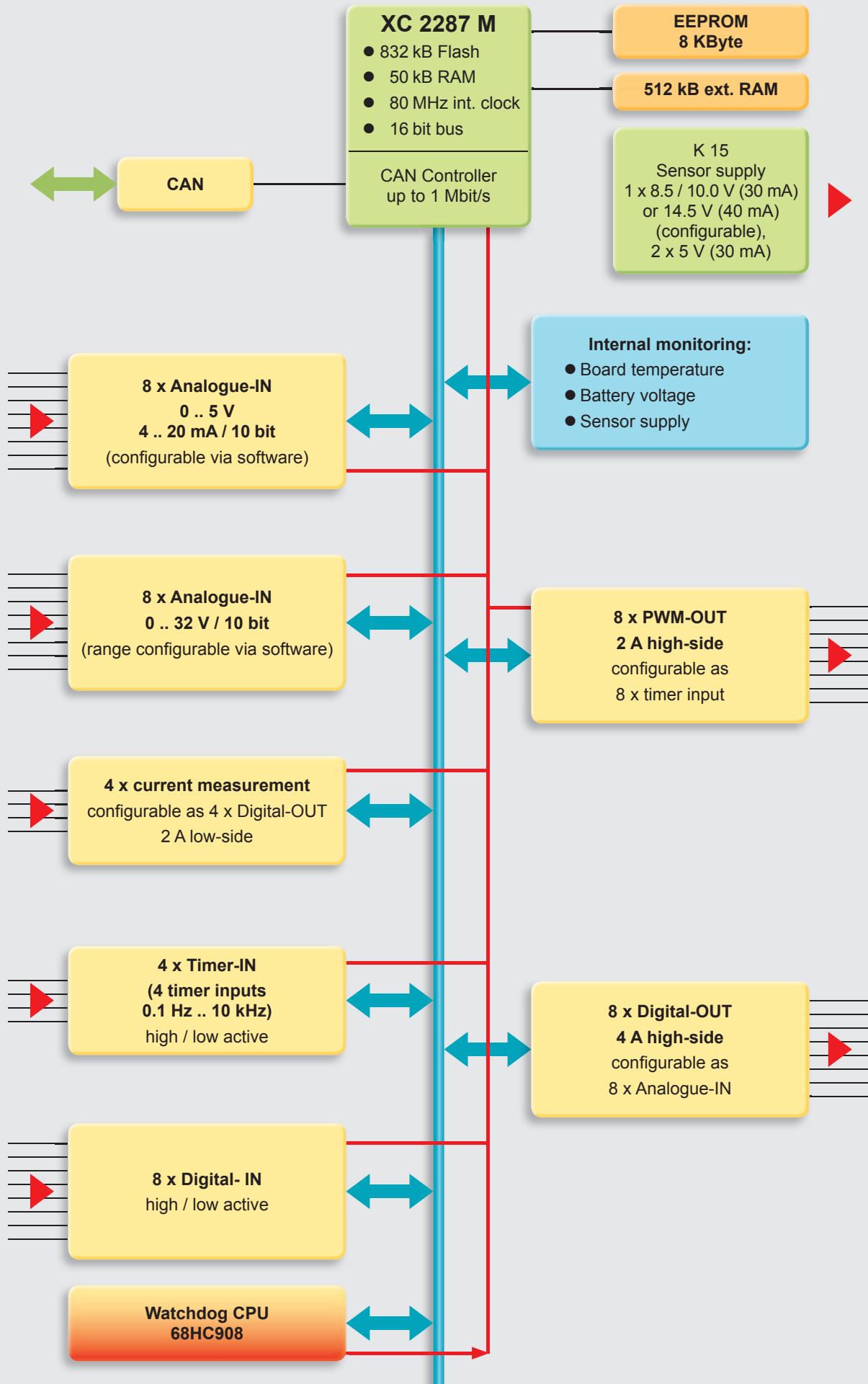

Model code

HY-TTC 48XS - 00 - Pd - 000

Equipment option

00 = standard

Functional safety

Pd = Performance Level d

Modification number

000 = standard

Note

On instruments with a different modification number, please read the label or the technical amendment details supplied with the instrument.

Accessories

Appropriate accessories, such as electrical connectors, service tools, software, etc. can be found in the Accessories section.

Note

The information in this brochure relates to the operating conditions and applications described.

For applications and operating conditions not described, please contact the relevant technical department.

Subject to technical modifications.

Dimensions

52-pole Tyco PN 1393450-5 / 28-pole Tyco PN 1393436-4

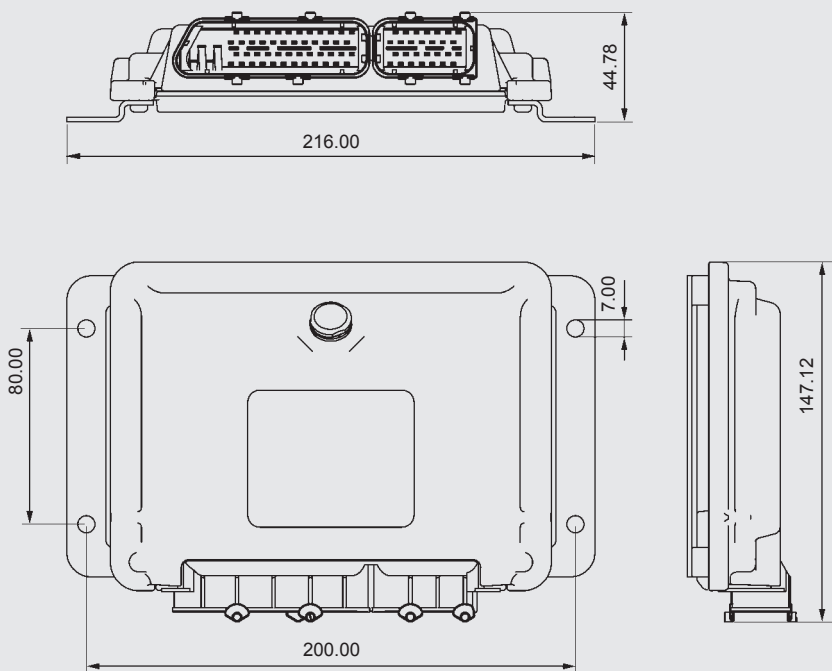

HYDAC ELECTRONIC GmbH

Hauptstraße 27, 66128 Saarbrücken

Tel. +49 (0)6897 509-01

Fax +49 (0)6897 509-1726

E-Mail: electronic@hydac.com

Internet: www.hydac.com