

Hydraulic Control Unit TTC 30



General Description

The TTC 30 is a compact control unit specially developed for use in cost-sensitive applications or smaller machines. The device is based on an Infineon XC22xx microcontroller and supports programming in C. With its 30 freely configurable I/Os it can be operated with a wide variety of sensors and actuators.

The 30 version is best suited for controlling proportional functions. Six out of the eight PWM outputs have integrated current measurement which means that, for example, up to three hydraulic axes can be current controlled. The TTC 30 was specially developed for vehicles and machines used in rugged operating environments and at extreme operating temperatures. The device is protected by a proven, robust and compact housing, specially designed for the off-highway industry.

Specifications

Parameter		Unit
ECU Dimensions	147 x 92 x 38	mm
Dimensions for Minimum Connector Release Clearance	208 x 92 x 38	mm
Weight	330	g
Connector	48	pins
Operating Temperature	- 40 to + 85	°C
Operating Altitude	0 to 4000	m
Supply Voltage	8 to 32	V
Peak Supply Voltage	40	V _{max}
Max Idle Current	≤120	mA
Standby Current	≤1	mA
Total Load Current	24	A _{max}
Standards		
Functional Safety	Designed for ISO 13849 PL b	
CE-Mark	2014/30/EU	
E- Mark	ECE-R10 Rev.5	
EMC	EN 13309 ISO 14982 CISPR 25 EN 61000-6-2/-4	
ESD	ISO 10605	
Electrical	ISO 16750-2 ISO 7637-2,-3, limited to 40 V by external load dump protection	
Ingress Protection	EN 60529 IP67 ISO 20653 IP6k9k	
Climatic	ISO 16750-4 EN 50581	
Mechanical	ISO 16750-3	

Features

CPU Core

- Infineon XC22xx 16/32-bit CPU running at 80 MHz
- 768 kByte int. Flash, 82 kByte int. RAM, 8 kByte EEPROM

Interfaces

- 1 x CAN, 125 kbit/s up to 1 Mbit/s,
- 1 x CAN bus termination configurable via connector pins

Outputs

- 6 x PWM OUT or digital OUT, up to 3 A, high side switch with current measurement, overload and open load detection alternative use digital timer IN (10 Hz - 10 kHz) or analog IN 0 - 32 V both with integrated Pull-Up
- 2 x PWM OUT or digital OUT, up to 3 A, high side switch with overload detection, open load detection and support for high inrush current loads alternative use digital timer IN (10 Hz - 10 kHz) or analog IN 0 - 32 V both with integrated Pull-Up
- 2 x digital OUT, up to 3 A, low side switch with overload and open load detection alternative use analog IN, 0 - 32 V with integrated Pull-Up
- 6 x PVG OUT
15 % - 85 % BAT+ with PVG valve alternative use voltage OUT 0 V - 75 % BAT+ with 10 kOhm low side load or analog IN 0 - 32 V

Inputs

- 4 x digital timer IN (0.1 Hz - 10 kHz) alternative use analog IN, 0 to 32V 1x rotary encoder configurable Pull-Up/Down in digital IN mode
- 2 x analog IN, configurable in software
0 - 5V / 10 V IN 0 - 25 mA IN
0 - 65 kOhm IN up to 25 mA LED control OUT
- 6 x analog IN, configurable in software
0 - 5V / 10 V IN 0 - 25 mA IN
up to 25 mA LED control OUT
- 2 x analog IN 0 - 32V configurable Pull-Up/Down in digital IN mode

Other

- 1 x sensor supply 5 V, 100 mA
- Internal monitoring of board temperature, sensor supply, terminal 15 input and battery voltage

Software

- Available with the software platform MATCH® by HYDAC Software.
- Programming: Board support package and driver library available for programming in 'C'

All I/Os and interfaces are protected against short circuit to GND and BAT+ and can be configured by software. All analog inputs use 10-bit resolution.

All analog voltage inputs can be used as digital inputs with configurable switching levels and hysteresis. Dedicated power supply pins for high side outputs. Details to the standards can be found in the user manual.

Block Diagram

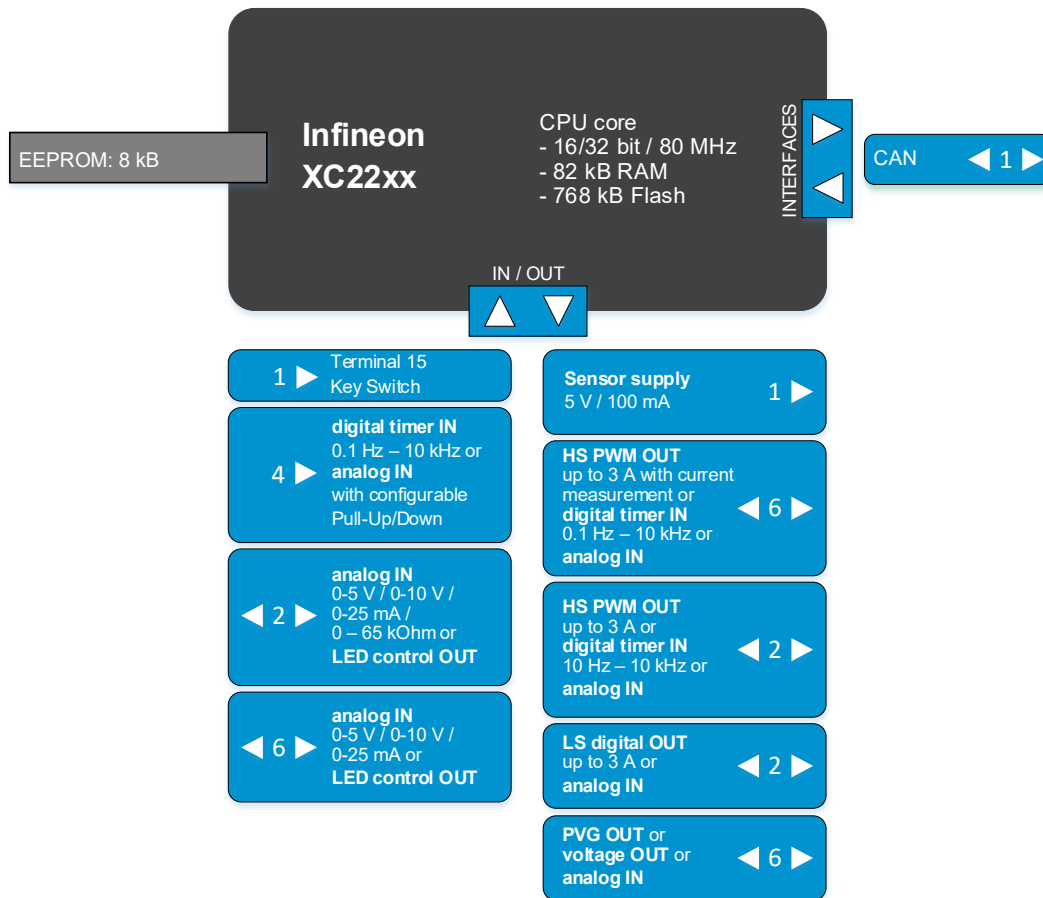

Housing and Connector

Aluminium die-cast housing

48-pin connector, 1 connector chamber

Mating connector: FCI PPI0001494 or PPI0001495
Molex 64320-1311 or 64320-3311

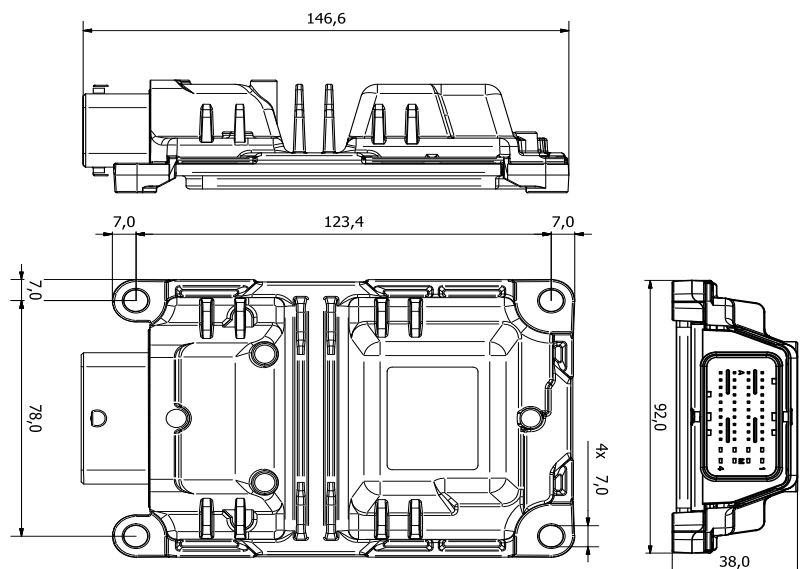

For further information, including price and availability, please contact products@ttcontrol.com.

Subject to changes and corrections. TTC 30H is a product name of TTControl GmbH. CODESYS® is a registered trademark of CODESYS GmbH. CANopen® and CiA® are registered community trademarks of CAN in Automation). All other trademarks are the property of their respective holders. To the extent possible under applicable law, TTControl hereby disclaims any and all liability for the content and use of this product flyer.