

## High Performance Safety Controller – TTC 590

### General Description

TTC 590 is a high-end electronic control solution for the off-highway industry satisfying all upcoming needs: The core of the controller is the very powerful TMS570 CPU designed for use in demanding safety-critical automotive and transportation applications. The TTC 590 fulfils safety requirements up to SIL 2 (IEC 61508), PL d (EN ISO 13849), AgPL d (ISO 25119 \*) and ASIL C (ISO 26262 \*).

The TTC 590 is part of a complete and compatible product family and is protected by a compact, automotive-style housing suited to mobile applications.

### Specifications

Parameter		Unit
ECU Dimensions	231.3 x 204.9 x 38.8	mm
Dimensions for minimum connector release clearance	315.3 x 204.9 x 38.8	mm
Weight	1200	g
Connector	154	pins
Operating Temperature	-40 to +85	°C
Operating Altitude	0 to 4000	m
Supply Voltage	8 to 32	V
Peak Supply Voltage	45	V <sub>max</sub>
Supply Current at 12/24V without load	400/200	mA <sub>max</sub>
Standby Current	<1	mA <sub>max</sub>
Total Load Current	60	A <sub>max</sub>

### Standards

Functional safety	IEC 61508 SIL2 EN ISO 13849 PL d ISO 25119 AgPL d * ISO 26262 ASIL C *
CE-Mark	2014/30/EU 2006/42/EC
E-Mark	ECE-R10 Rev.4
EMC	EN 13309 ISO 14982 CISPR 25 EN 61000-6-2/-4
ESD	ISO 10605
Electrical	ISO 16750-2 ISO 7637-2,-3
Ingress Protection	EN 60529 IP67 ISO 20653 IP6k9k
Climatic	ISO 16750-4 EN 50581
Mechanical	ISO 16750-3
ISOBUS	ISO 11783

### Software

- C-Programming environment
- SAFERTOS® Integration, as extension of C-Programming environment
- CODESYS® Safety SIL 2 including support for CANopen® Safety Master
- CODESYS® V3 including support for CANopen® Master



### Features

#### CPU Core

- 32-Bit TI TMS570, ARM cortex-R4F based
- Dual-core lockstep CPU and memory protection for safety-relevant applications
- 180 MHz, 298 DMIPS, Floating-Point Unit
- 3 MB int. Flash, 256 kB int. RAM
- 32 MB ext. Flash, 2 MB ext. RAM, 32 kB ext. FRAM
- Safety Companion CPU

#### Interfaces

- 6 x CAN 50 kbit/s up to 1 Mbit/s
- 1 x CAN ISOBUS
- 4 x CAN bus termination configurable via connector pins
- 1 x 100BASE-T1 BroadR-Reach®
- 1 x LIN, 1 x RS232
- 1 x Real Time Clock

#### Outputs

- 36 x PWM OUT or digital OUT, up to 4 A, high side, with high side current measurement  
8 of these outputs can be alternatively used as digital timer IN (0.1 Hz - 10 kHz)
- 8 x digital OUT up to 4 A, high side, overload and open load detection, current sense  
alternative use as LED control OUT or analog IN 12 bit, 0 – 32 V with configurable pull-up/down
- 8 x digital OUT up to 4 A, low side, current sense, overload and open load detection,  
alternative use as analog IN 12 bit, 0 – 32 V
- Wiring option to use up to 8 of the digital OUT, high side and 8 digital OUT, low side, as full H-bridge for motor control

#### Multi-purpose I/O's

- 8 x configurable as
  - PVG OUT, 10 - 90% of BAT+ or
  - voltage OUT, 0 - 100% of BAT+ or
  - digital OUT up to 4 A high side or
  - LED control OUT or
  - analog IN 12 bit, 0 - 32 V

#### Inputs

- 8 x analog IN 12 bit, 0 - 5 V, 0 - 25 mA, 0 - 100 kOhm
- 8 x analog IN 12 bit, 0 - 5 V, 0 - 10 V, 0 - 25 mA
- 8 x analog IN 12 bit, 0 - 5 V, 0 - 32 V, 0 - 25 mA
- 6 x digital timer IN (0.1 Hz - 20 kHz), encoder supporting digital voltage sensors with configurable pull-up/down, digital (7/14 mA) current loop speed-sensor  
alternative use as analog IN 12 bit, 0 – 32 V
- 6 x digital timer IN (0.1 Hz - 20 kHz), encoder supporting digital voltage sensors with configurable pull-up/down,  
alternative use as analog IN 12 bit, 0 – 32 V
- Terminal 15 and wake up

#### Sensor supply

- 2 x sensor supply, 5 V, max. 500 mA
- 1 x sensor supply, 5 – 10 V, max. 2.5 W, configurable by SW in 1 V steps

All I/Os and interfaces are protected against short circuit to GND and BAT+ and can be configured by software.

Board temperature, sensor supply and supply voltage are monitored by software.

Inputs and Outputs can also be used as digital Input.

Three independent shut-off groups for PWM output stages.

Details to the standards can be found in the System-Manual.

\* Available for C-Programming environment only.

**Block Diagram**

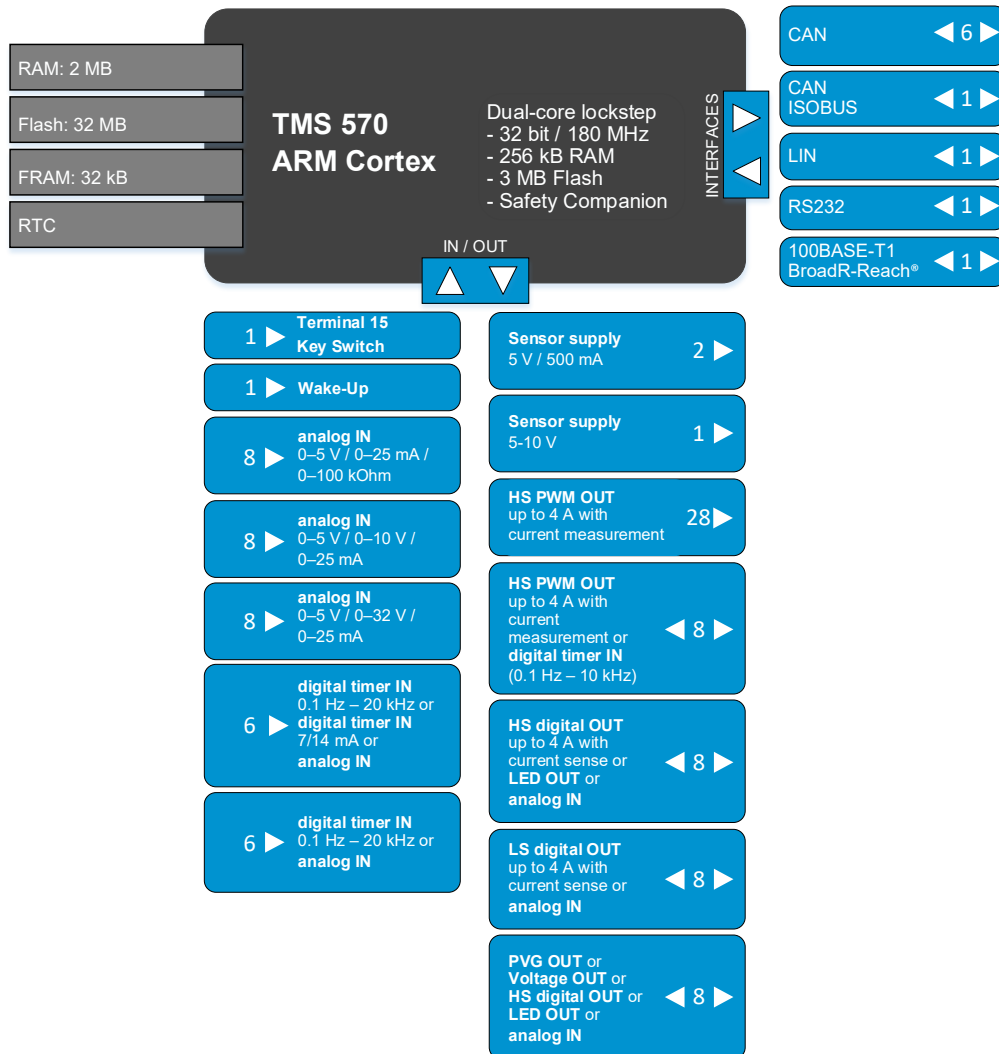

**Housing and Connector**

Aluminium die-cast housing

154-pin connector

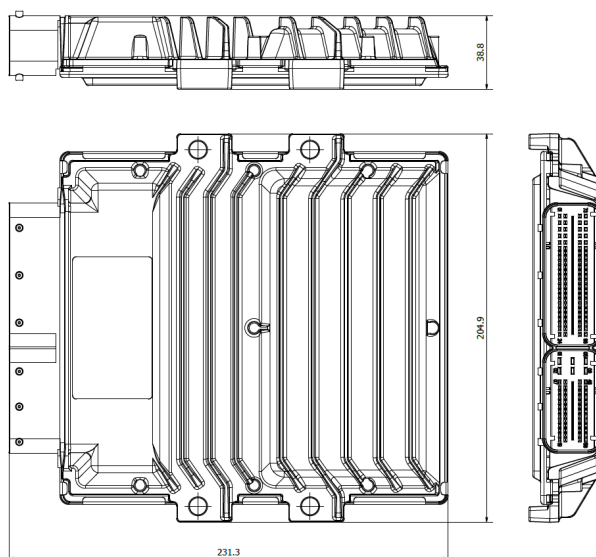

For further information, including price and availability, please contact [products@ttcontrol.com](mailto:products@ttcontrol.com)

Subject to changes and corrections. TTC 590 is a product name of TTControl GmbH. CODESYS® is a registered trademark of CODESYS GmbH. CANopen® and CiA® are registered community trademarks of CAN in Automation). All other trademarks are the property of their respective holders. To the extent possible under applicable law, TTControl hereby disclaims any and all liability for the content and use of this product flyer.