

Compact Safety Electronic Control Unit – TTC 2038

General description

The TTC 2038 is a robust and powerful compact electronic control solution for off-highway applications. The TTC 2038 is equipped with Infineon's TriCore™ Aurix™ TC367 CPU and designed to fulfil the requirements of demanding safety-relevant off-highway and automotive applications.

The TTC 2038 is part of a complete and compatible product range for the off-highway and automotive industry. The module is protected by a compact automotive style housings which is perfectly suited for harsh operating conditions.

Specifications

Parameter		Unit
Ecu dimensions	147 x 92 x 38	mm
Dimensions for minimum connector release clearance	208 x 92 x 38	mm
Weight	330	g
Connector	1 x 48	pins
Operating temperature	-40 to +85	°C
Operating altitude	0 to 4000	m
Supply voltage	8 to 32	V
Supply current at 12/24V without load	200/100	mA _{max}
Standby current	≤ 0,8	mA _{max}
Total load current	24	A _{max}

Standards

Functional safety	IEC 61508 SIL2 EN ISO 13849 PL d ISO 25119 AgPL d SRL2	ISO 26262 ASIL C ISO 19014 MPL d
CE	2014/30/EU 2006/42/EC 2011/65/EU	
UKCA	SI 2016 no.1091 SI 2008 no.1597 SI 2012 no. 2032	
E-Mark	ECE-R10 Rev.6	
FCC	47 CFR Part 15B, Class A	
EMC	EN 13766 ISO 14982 CISPR 25	IEC 61000-4-2/-3/-4/-5/-6/-8 IEC 61000-6-4
ESD	ISO 10605	
Electrical	ISO 16750-2 ISO 7637-2, -3, limited to 58 V by external load dump protection	
Ingress protection	EN 60529 IP65 and IP67 ISO 20653 IP6k9k	
Climatic	ISO 16750-4	
Mechanical	ISO 16750-3	
ISOBUS	ISO 11783	

Board temperature, sensor supply and supply voltage are monitored by software.

One safety shut-off group for output stages is available.

Details to the standards can be found on the system manual.

Software:

- C Programming Environment featuring RTOS support
- CODESYS® V3 including support for CANopen® Master*
- CODESYS® Safety SIL 2 including support for CANopen® Safety Master*



Features

CPU Core

- 32-Bit Infineon TriCore™ Aurix™ TC367
- 2 cores (lockstep cores) running at 300 MHz and memory protection for safety-relevant applications
- Floating-Point Unit and Hardware Security Module
- 576 KB int. SRAM, 4 MB int. Flash
- 128 KB int. EEPROM emulation

Interfaces

- 2 x CAN FD 50 kbit/s up to 2 Mbit/s (1 x CAN FD with wake-up capability and 1 x CAN FD ISOBUS)
- 4 x SENT with SPC support
- 1 x LIN

Outputs

- 8 x PWM OUT up to 1 kHz or digital OUT, up to 4 A, high side, with current measurement, alternative use as digital timer IN (0.1 Hz - 20 kHz) configurable pull-up in groups of 2 or analog IN 12 bit, 0 - 32 V with configurable pull-up or LED control OUT
- 6 x digital OUT up to 4 A, high side, current sense alternative use as PVG OUT, 10 - 90% of BAT+ or voltage OUT 0 V - 75 % BAT+ or LED control OUT or analog IN 12 bit, 0 - 32 V or 1 x as emergency stop OUT
- 2 x PWM OUT up to 4 kHz, up to 4 A, low side, current measurement, featuring timer feedback, alternative use digital timer IN (0.1 Hz - 20 kHz) or analog IN 12 bit, 0 - 5 V, 0 - 32 V

Inputs

- 8 x analog IN 12 bit, 0 - 5 V with configurable pull-up/down, 0 - 25 mA, 0 - 100 kOhm, LED control
- 2 x analog IN 12 bit, 0 - 5 V, 0 - 32 V with configurable pull-up/down or emergency stop IN
- 2 x digital timer IN (0.1 Hz - 20 kHz), encoder support, configurable pull-up/down, support for 7/14 mA current loop speed-sensor alternative use as analog IN 12 bit, 0 - 32 V, 0 - 25 mA
- 4 x digital timer IN (0.1 Hz - 20 kHz), encoder support, configurable pull-up alternative use as analog IN 12 bit, 0 - 32 V or SENT interface or digital IN for switching to GND and BAT+
- 1 x Terminal 15
- 1 x Wake-Up

Sensor supply

- 1 x sensor supply, 5 V, max. 150 mA

All inputs and outputs supporting analog IN can also be used as digital Input.

All I/Os and interfaces are protected against short circuit to GND and BAT+ and can be configured by software.

* upcoming feature

Block diagram

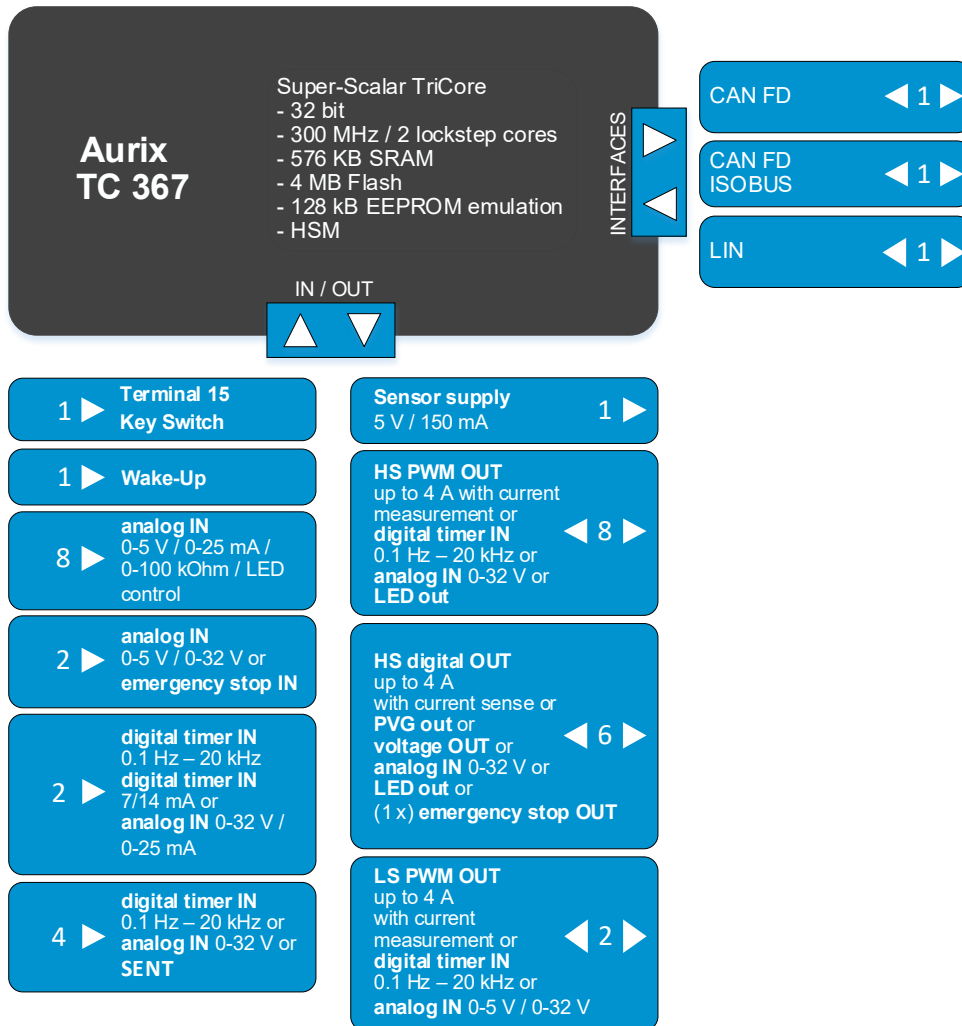

Housing and connector

Aluminum die-cast housing

1 x 48 pin connector

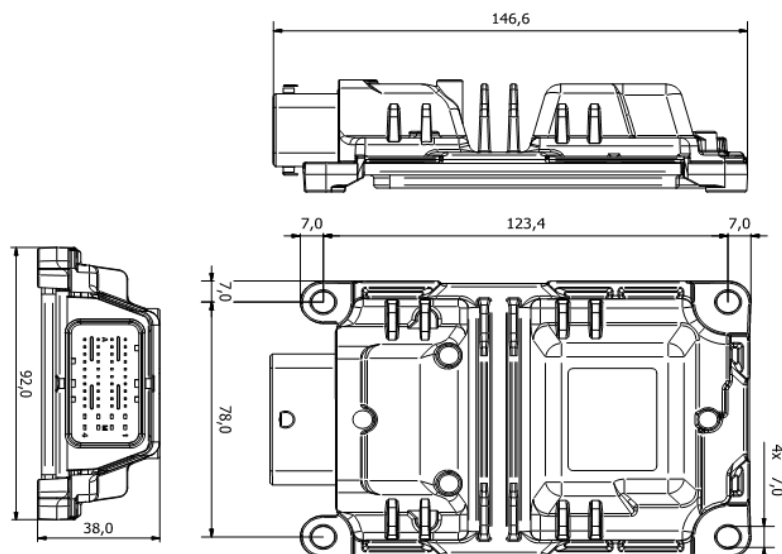

For further information, including price and availability, please contact products@ttcontrol.com

Subject to changes and corrections. TTC 2038 is a product name of TTControl GmbH. CODESYS is a trademark of 3S Smart Software Solutions GmbH. CANopen is a trademark of CAN in Automation (CiA). All other trademarks are the property of their respective holders. To the extent possible under applicable law TTControl hereby disclaims any and all liability for the content and use of this product flyer.